

BK17LLAST

January 1991

B



Defense Language Institute
English Language Center
Lackland Air Force Base, Texas

AMERICAN LANGUAGE COURSE



LEVEL III

BOOK 17

LANGUAGE LABORATORY ACTIVITIES

STUDENT TEXT

BK17LLAST

January 1991

B



**Defense Language Institute
English Language Center
Lackland Air Force Base, Texas**

AMERICAN LANGUAGE COURSE



LEVEL III

BOOK 17

LANGUAGE LABORATORY ACTIVITIES

STUDENT TEXT

PREFACE

The American Language Course (ALC) is designed primarily for an intensive language training program. However, these materials can also be used in nonintensive programs. The course will provide students with a sufficient level of fluency and communicative proficiency in American English to enable them to successfully pursue technical or professional training in schools conducted by the Department of Defense.

The General English Phase of the ALC consists of six progressive levels of language proficiency training. Levels I through V consist of six separate instructional packages each. Level VI contains four.

Level I	Books 1 - 6
Level II	Books 7 - 12
Level III	Books 13 - 18
Level IV	Books 19 - 24
Level V	Books 25 - 30
Level VI	Books 31 - 34

The coordinated instructional packages for Books 1-30 consist of the following:

1. Instructor Text
2. Student Text
3. Audiotapes
4. Instructor Language Laboratory Activities Booklet
5. Student Language Laboratory Activities Booklet
6. Quiz Kits
7. Optional training aids

Inquiries concerning these materials, including requests for copies, should be addressed to Commandant, Defense Language Institute English Language Center, ATTN: LERW, 2235 Andrews Ave., Lackland Air Force Base, Texas 78236-5259.

Recommendations for improving this edition are encouraged. Letters should be addressed to: Commandant, Defense Language Institute English Language Center, ATTN: LEAC, 2235 Andrews Ave., Lackland Air Force Base, Texas 78236-5259.

The American Language course (ALC) contains copyrighted material. Reproduction of this publication is not authorized without the expressed written permission of the owners of the copyrights.

NOTES TO THE STUDENT

This booklet contains the Language Laboratory Activities (LLA) for Book 17.

You will need a pen or pencil and this booklet to do the activities correctly. All directions are given orally on the tapes. It is important to listen carefully to the instructions and to do the things the tape tells you to do. You will be told to repeat words or sentences and to ask and answer questions. You will also be told to choose and mark certain words or expressions, or to write special words, phrases, or sentences. Most of the time the tape will give you the correct answers right away, so you can check your work. Sometimes the tape will tell you to look on a certain page for the answers. Relax, listen carefully, and respond!

DISTRIBUTION OF OBJECTIVES IN THE
LANGUAGE LABORATORY ACTIVITIES FOR BOOK 17

LESSON 1

TAPE 1A (ST p. 1)

- | | |
|----------|--|
| Figure 1 | Reading Skill (written phrase/S D) |
| Figure 2 | Grammar (linking verbs + like + noun phrase) |
| Figure 3 | Listening Skill (dialog/write the number) |
| Figure 4 | Vocabulary Review (past participle of verbs) |
| Figure 5 | Reading Skill (main idea/select) |
| Figure 6 | Vocabulary |
| Figure 7 | Listening Skill (announcement/select answer) |

TAPE 1B (ST p. 5)

- | | |
|-------------|--|
| Figures 1-3 | Function (making observations and judgments) |
| Figure 4 | Grammar (reported speech/if-whether questions) |
| Figure 5 | Vocabulary |
| Figure 6 | Listening Skill (inference/select) |
| Figure 7 | Listening Skill (main idea/write) |

TAPE 1C (ST p. 9)

- | | |
|----------|--|
| Figure 1 | Grammar (to be + seem/appear) |
| Figure 2 | Listening Skill (listen for specific info) |
| Figure 3 | Writing Skill (write messages) |
| Figure 4 | Listening Skill (inference/select) |
| Figure 5 | Vocabulary (past participle review) |
| Figure 6 | Listening Skill (topic/write) |
| Figure 7 | Listening Skill (true statement/oral text) |
| Figure 8 | Listening Skill (announcement/select answer) |

TAPE 1D (ST p. 15)

- | | |
|----------|--|
| Figure 1 | Vocabulary |
| Figure 2 | Listening Skill (info not in text/select) |
| Figure 3 | Listening Skill (announcement/select) |
| Figure 4 | Grammar (-tion/-sion) |
| Figure 5 | Vocabulary |
| Figure 6 | Listening Skill (dialog/write numbers) |
| Figure 7 | Writing Skill (conversation/write message) |

LESSON 2

TAPE 2A (ST p. 21)

Figures 1-4	Vocabulary
Figures 5-6	Listening Skill (dialog/take part)
Figure 7	Reading Skill (word that doesn't belong)

TAPE 2B (ST p. 27)

Figures 1-2	Vocabulary
Figures 3-4	Reading Skill (word about the same meaning)
Figures 5-6	Grammar (compound pre-modifiers)
Figure 7	Writing Skill (dictation/missing words)

TAPE 2C (ST p. 33)

Figure 1	Listening Skill (announcement/select)
Figure 2	Listening Skill (message/write)
Figure 3	Grammar (if-whether/embedded questions)
Figure 4	Grammar (question words/embedded questions)

TAPE 2D (ST p. 37)

Figures 1-2	Listening Skill (scan/provide answers)
Figure 3	Grammar (object/adjective complement)
Figures 4-6	Function (renting an apartment)
Figure 7	Writing Skill (complete the outline)

LESSON 3

TAPE 3A (ST p. 43)

Figures 1-4	Vocabulary
Figures 5-6	Grammar (BE passive with modals)
Figure 7	Reading Skill (word which does not belong)

TAPE 3B (ST p. 51)

Figures 1-4	Vocabulary
-------------	------------

TAPE 3C (ST p. 55)

- Figure 1 Vocabulary
Figures 2-4 Grammar (infinitive as direct object)
Figure 5 Writing Skill (announcement/write answer)

TAPE 3D (ST p. 61)

- Figure 1 Listening Skill (inference/select)
Figures 2-3 Grammar (clauses of contrast/concession)
Figure 4 Listening Skill (inference/select)
Figure 5 Writing Skill (dictation/missing words)

LESSON 4

TAPE 4A (ST p. 67)

- Figures 1-2 Vocabulary
Figure 3 Grammar (suffix -en)

TAPE 4B (ST p. 73)

- Figure 1 Vocabulary
Figure 2 Grammar (either/neither)
Figure 3 Listening Skill (announcement/write answer)

TAPE 4C (ST p. 79)

- Figures 1-2 Grammar (tag questions)
Figures 3-4 Speaking Skill (dialog/take part)
Figures 5-6 Listening Skill (announcement/provide answer)
Figure 7 Vocabulary (review)

TAPE 4D (ST p. 85)

- Figures 1-6 Function/Listening Skill (checking info/
dialog/take part)
Figures 7-8 Writing Skill (complete the outline)
Figure 9 Writing Skill (dictation/paragraph)
Figures 10-11 Listening Skill (announcement/provide answer)

LANGUAGE LABORATORY ACTIVITIES, TAPE 1A, BOOK 17

Figure 1

1.	on a list	enlist	S	D
2.	demanded a raise	demanded a race	S	D
3.	an adjustment	an adjustment	S	D
4.	a neat table	a meat table	S	D
5.	hardworking woman	handsome man	S	D
6.	this honest man	the dishonest man	S	D
7.	denied her request	denied his request	S	D
8.	to a sign	to assign	S	D
9.	unable to explain	unable to explain	S	D
10.	properly rest	proper rest	S	D
11.	computer education	compulsory education	S	D
12.	performance rating	performance data	S	D
13.	yell and scream	yellow screen	S	D
14.	assembled the pants	assembled the parts	S	D
15.	a red beard	a redhead	S	D

TAPE 3C (ST p. 55)

- | | |
|-------------|---|
| Figure 1 | Vocabulary |
| Figures 2-4 | Grammar (infinitive as direct object) |
| Figure 5 | Writing Skill (announcement/write answer) |

TAPE 3D (ST p. 61)

- | | |
|-------------|--|
| Figure 1 | Listening Skill (inference/select) |
| Figures 2-3 | Grammar (clauses of contrast/concession) |
| Figure 4 | Listening Skill (inference/select) |
| Figure 5 | Writing Skill (dictation/missing words) |

LESSON 4

TAPE 4A (ST p. 67)

- | | |
|-------------|----------------------|
| Figures 1-2 | Vocabulary |
| Figure 3 | Grammar (suffix -en) |

TAPE 4B (ST p. 73)

- | | |
|----------|---|
| Figure 1 | Vocabulary |
| Figure 2 | Grammar (either/neither) |
| Figure 3 | Listening Skill (announcement/write answer) |

TAPE 4C (ST p. 79)

- | | |
|-------------|---|
| Figures 1-2 | Grammar (tag questions) |
| Figures 3-4 | Speaking Skill (dialog/take part) |
| Figures 5-6 | Listening Skill (announcement/provide answer) |
| Figure 7 | Vocabulary (review) |

TAPE 4D (ST p. 85)

- | | |
|---------------|---|
| Figures 1-6 | Function/Listening Skill (checking info/
dialog/take part) |
| Figures 7-8 | Writing Skill (complete the outline) |
| Figure 9 | Writing Skill (dictation/paragraph) |
| Figures 10-11 | Listening Skill (announcement/provide answer) |

LANGUAGE LABORATORY ACTIVITIES, TAPE 1A, BOOK 17

Figure 1

1.	on a list	enlist	S	D
2.	demanded a raise	demanded a race	S	D
3.	an adjustment	an adjustment	S	D
4.	a neat table	a meat table	S	D
5.	hardworking woman	handsome man	S	D
6.	this honest man	the dishonest man	S	D
7.	denied her request	denied his request	S	D
8.	to a sign	to assign	S	D
9.	unable to explain	unable to explain	S	D
10.	properly rest	proper rest	S	D
11.	computer education	compulsory education	S	D
12.	performance rating	performance data	S	D
13.	yell and scream	yellow screen	S	D
14.	assembled the pants	assembled the parts	S	D
15.	a red beard	a redhead	S	D

Figure 2

EXAMPLES: She seems like an unselfish woman. (good doctor)
She seems like a good doctor.

He looks like a salesman. (his brother)
He looks like his brother.

I feel like a million dollars! (a young person again)
I feel like a young person again.

This room smells like old fish. (strawberries)
This room smells like strawberries.

The soup tastes like onions. (oranges)
This soup tastes like oranges.

.....

Figure 3

1. _____
2. _____
3. _____

.....

Figure 4

EXAMPLES: Please take the engine apart.
It's already taken apart.

Please copy these letters.
They're already copied.

Figure 5

- a. Tim Brown is learning to be a singer.
- b. Tim Brown is a hardworking, popular singer.
- c. Tim Brown is a handsome and popular singer.
- d. Tim Brown sings extremely well.

.....

Figure 6

- 1. unselfish character
Lt Gregory has an unselfish character. He's always ready to help.
- 2. elderly...gray
Ann is 75 years old. She's elderly. She has gray hair.
- 3. demand
The drill sergeant wanted an explanation. He demanded it.
- 4. demand
His demands weren't reasonable.
- 5. personality
Everyone likes Pam. She has a great personality.
- 6. glasses
John can't see without his glasses.
- 7. rely on
Can we rely on your friend to take good care of our child?
- 8. handsome
Some men are handsome; some women are pretty.
- 9. messy/neat
Is her desk clean? No, it's messy; it's not neat.
- 10. trust
He's a responsible person. You can trust him.
- 11. wavy
His hair isn't straight; it's wavy.
- 12. scream
She saw a mouse and she screamed.

1. What time do performances begin?
 - a. 8:30 p.m.
 - b. 8:15 p.m.
 - c. 7:30 p.m.
 - d. 8:00 p.m.

2. What kind of performance is it?
 - a. an opera
 - b. a play
 - c. a musical comedy
 - d. a concert

3. What days will performances take place?
 - a. Wednesday, Thursday, and Friday
 - b. Friday Saturday, and Sunday
 - c. Thursday, Friday, and Sunday
 - d. Thursday, Friday, and Saturday

Figure 1

Frank: My daughter's met a man she wants to marry.

Frances: Oh, really? What do you think of him?

Frank: I won't say I dislike him, but I'm not sure I like him either.

Frances: What kind of a person is he?

Frank: Well, I can't deny he has a pleasant personality and a nice appearance, but I want to know more about his character before I give my OK to a wedding.

.

Figure 2

1. What are they talking about? _____
2. Who does Linda feel angry with? _____
3. What does Linda's dad want to know about Ted? _____

Figure 3

Linda wants to get married. Her father _____ she
1
should be cautious _____ such an important decision.
2
_____ asked her whether she _____ to marry a man
3 4
_____ knowing if he was _____. He doesn't want
5 6
her _____ marry someone who might _____ irresponsible,
7 8
someone who might make her life unhappy.

.

Figure 4

1. if she wanted to get married
2. whether she could trust Ted
3. if she liked Ted
4. No, Ted asked Linda to marry him.
5. whether Linda was going to marry Ted

Figure 5

EXAMPLES: Ralph is very responsible. (reliable)

Ralph is very reliable.

Carlos has curly hair. (wavy)

Carlos has wavy hair.

You can depend on Dan. (rely on)

You can rely on Dan.

.....

Figure 6

1.
 - a. on a bus
 - b. on a boat
 - c. on a plane
 - d. on a train

2.
 - a. a visa application
 - b. a job application
 - c. an application to graduate school
 - d. a loan application

3.
 - a. an important game
 - b. an important meeting
 - c. an important decision
 - d. an important test

Figure 7

1. _____

2. _____

3. _____

4. _____

5. _____

Figure 1



1. Linda seems to be ready.



2. They appear to be students.



3. He seems to be a pilot.



4. There seems to be an emergency.



5. Ted appears to be irresponsible.



6. Al doesn't appear to be stingy.



7. This seems to be an empty seat.

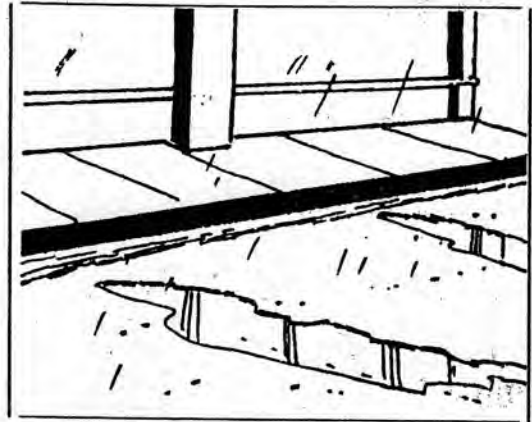

8. The street appears to be wet.



9. He appears to be a generous man.



10. She seems to be selfish and demanding.



11. There appears to be a problem.

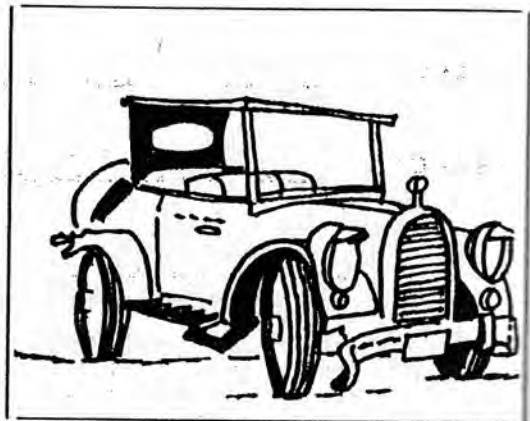

12. It doesn't seem to be a new car.

Figure 2

1. _____

2. _____

.....

Figure 3

1. For: _____

From: _____

Message: _____

2. For: _____

From: _____

Message: _____

3. For: _____

From: _____

Message: _____

Figure 4

- | | | | |
|----|--------------------|----|------------------|
| 1. | a. office manager | 2. | a. too low |
| | b. service manager | | b. normal |
| | c. computer clerk | | c. a little high |
| | d. office clerk | | d. too high |
| 3. | a. 2 weeks | 4. | a. 2 |
| | b. 4 weeks | | b. 3 |
| | c. 4 nights | | c. 4 |
| | d. 3 days | | d. 1 |

.....

Figure 5

EXAMPLES: The machines are turned off.
Someone turned off the machines.

The computers are shut down.
Someone shut down the computers.

.....

Figure 6

1. _____

Figure 7

1. a. Dolphins are friendly to people.
b. Dolphins are afraid of people.
c. Dolphins are not intelligent.
-

Figure 8

1. a. Lt Gen Allen
b. Maj Gen Allen
c. Major Allen
d. Brig Gen Allen
2. a. the south parade grounds
b. the north soccer field
c. the north parade grounds
d. the north soccer grounds
3. a. graduation
b. promotion
c. anniversary
d. retirement

Figure 1

Examples:



Is Mark friendly?
No, he's very unfriendly.



Is it an attractive house?
No, it's a very ugly house.



1. Is Margaret stingy?



2. Is Robert messy?

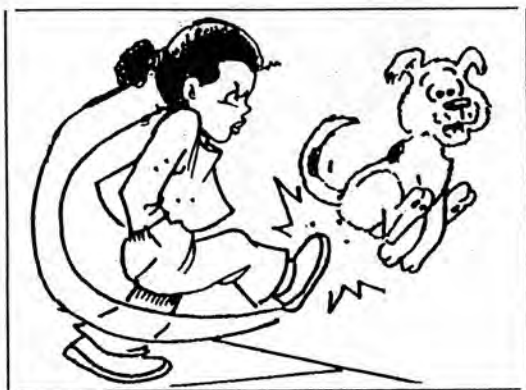

3. Is Alicia kind?



4. Is Alan clever?



5. Is Wanda's hair wavy?



6. Is the teacher demanding?



7. Is the drill sergeant lazy?

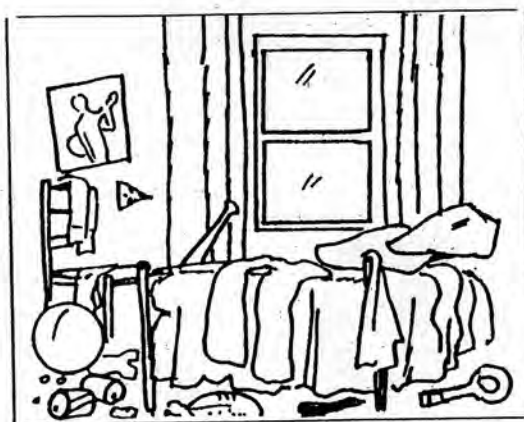

8. Is this a neat room?



9. Is William an unfriendly person?



10. Is Jane a dull student?

Figure 2

1. a. Dogs can learn to obey commands.
b. Dogs are rather intelligent.
c. Dogs can learn to crawl on their stomachs.
-

Figure 3

1. What time will the concert be?
 - a. 2:00 p.m.
 - b. 3:00 p.m.
 - c. 3:00 a.m.
 - d. 2:30 p.m.

2. Where will the concert be?
 - a. Carter Cultural Center
 - b. Carson Cultural Center
 - c. Carver Cultural Center
 - d. Curtain Cultural Center

3. What is the name of the orchestra?
 - a. Lucas Emanuel and His String Orchestra
 - b. Lucas Emanuel and His Classical Orchestra
 - c. Lucas Emanuel and His Musical Orchestra
 - d. Emanuel Lucas and His String Orchestra

Figure 4

EXAMPLE: The doctor will operate on Mrs. Wilson next week.

Mrs. Wilson's operation will be next week.

1. The _____ to extra weight is regular exercise.
2. The _____ of your health may begin with eating too much.
3. The _____ of food into four basic groups makes it easy to plan a healthy diet.
4. The _____ of a new food into your diet may cause an allergy.
5. Weight _____ may begin when you start a regular exercise program.
6. If your _____ is to lose weight, cut down on the amount of food you eat.
7. When you make a _____ to take care of your health, you will give up smoking.
8. The doctor's _____ may be regular exercise if you need to lose weight.
9. The _____ of a few simple health rules will help you to feel better and live longer.

Figure 5



a. _____



b. _____

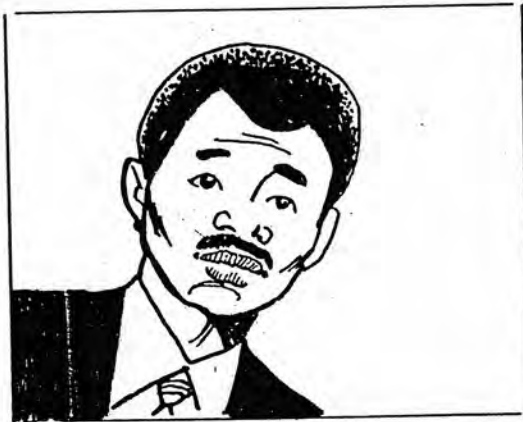

c. _____



d. _____



e. _____



f. _____

Figure 6

1. _____
2. _____
3. _____
4. _____

.....

Figure 7

1. For: _____
From: _____
Message: _____

2. For: _____
From: _____
Message: _____

Figure
small
watch
ad ca
they
don't
refri
condi
bills
elect
have
avail
trans
only
can g
going

Figure 1

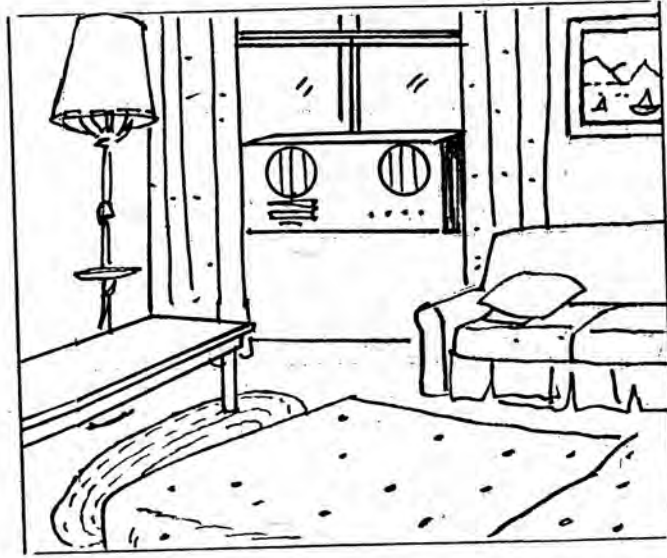

Ken and Karrie live in an efficiency apartment. It's too small for them, so they want to find a new apartment. They've been watching the advertisements in the newspaper closely, reading each ad carefully. They are looking for an unfurnished place because they have their own living room and bedroom furniture, but they don't have the big kitchen appliances, like a stove and refrigerator. They want to have central heating and air conditioning rather than window air conditioners. The utility bills may be higher with central air, because it uses more electricity, but they don't care. It's more important to them to have the good service of a central heater and air conditioner available than to pay lower bills. They need to have public transportation available, too, because they both work and they have only one car. They can take turns riding the bus to work if they can get an apartment close to a bus stop. They are going to have a hard time finding exactly what they want.

Figure 2

1.
 - a. in a small house
 - b. in a large apartment
 - c. in a one-room apartment

2.
 - a. newspaper ads
 - b. television advertisements
 - c. commercials

3.
 - a. an apartment with everything
 - b. an apartment with furniture
 - c. an apartment without furniture

4.
 - a. bedroom furniture
 - b. a stove and refrigerator
 - c. a heater and refrigerator

5.
 - a. the food bills
 - b. the electricity bills
 - c. the furniture bills

6.
 - a. one that's a part of the apartment
 - b. one that fits in a window
 - c. one that only cools the kitchen

7.
 - a. a second car for their use
 - b. a ride to work from a friend
 - c. a bus stop near their home

Figur

what
adve
to l
north
and
Rent
for
the
inclu
The
furn
paint
under

Figure 3

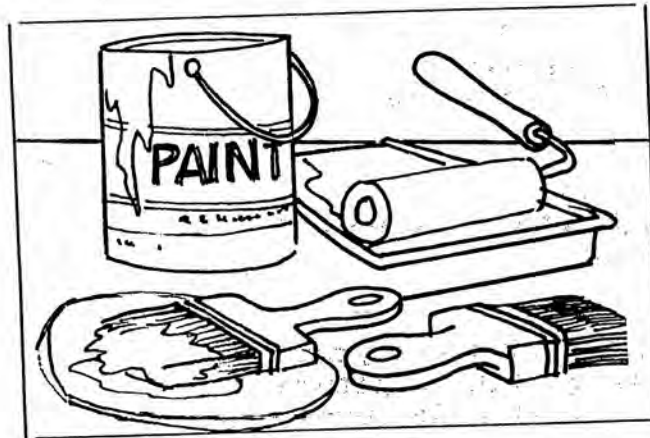

Ken and Karrie couldn't find an apartment that was exactly what they wanted, the perfect place for them, so they decided to advertise. They wrote their ad for the paper. It read: "Wanted to lease: A one-bedroom, one-bath unfurnished apartment in the northwest section of town, furnished with large kitchen appliances and central air and heat, near public transportation, water paid. Renter willing to paint the walls of all the rooms before moving in for a percentage off the deposit." They took the advertisement to the newspaper. The clerk helped them write the ad, so it would include all they wanted it to and exclude the unnecessary words. The new ad read: "Wanted to lease: 1 bdrm, 1 bth apt; nw sec; furn w/lge kit appl's & c/a/h; nr pub trans; wtr pd. Willing to paint for % off dep." Ken and Karrie wondered if the ad would be understood and answered.

Figure 4

1. a. No, they couldn't find the most expensive place.
b. No, they couldn't find the perfect place.
c. No, they couldn't find the cheapest place.

2. a. They put an ad in the paper.
b. They wrote to their friends.
c. They drove around town.

3. a. buy a one-bedroom, one-bath apartment
b. rent a one-bedroom, one-bath apartment
c. rent a furnished apartment

4. a. far from the northwest part of town
b. near the northwest section of town
c. in the northwest part of town

5. a. furniture for the living room
b. large appliances for the kitchen
c. small appliances for the kitchen

6. a. clean the walls
b. change the color of the walls
c. cover the walls with paper

7. a. She included what they wanted and kept in the unnecessary words.
b. She argued with what they wanted and left in the unnecessary words.
c. She included what they wanted and left out the unnecessary words.

8. a. They wanted to know if the ad would be understood and answered.
b. They were sure the ad would be understood and answered.
c. They argued that the ad wouldn't be understood or answered.

Figure 5

John: What does Jan feel like cooking for supper?
Jill: Nothing. She feels like eating out.

.

Figure 6

Cathy: That record sounds like it's very old.
Cory: It looks like it is, too.

Cathy: Do you feel like listening to it again?
Cory: Yes, I'd like to. It doesn't seem like I've heard it before.

Cathy: I don't think I have either.
Cory: Well, let's hear it again.

.

Figure 7

- EXAMPLE: red blue paper green yellow black
1. electricity gas water paint utilities
 2. generous demanding dependable dishonest elderly
 3. heater equipment transportation refrigerator appliance
 4. performance bus transportation taxi vehicle
 5. computer puzzle typewriter keyboard printer
 6. relaxing entertaining recruiting enjoying resting
 7. piano drums guitar printer violin
 8. musical orchestra drama opera comedy
 9. steak potatoes vegetables wine fruit
 10. medicine pills tablets prescriptions doctors

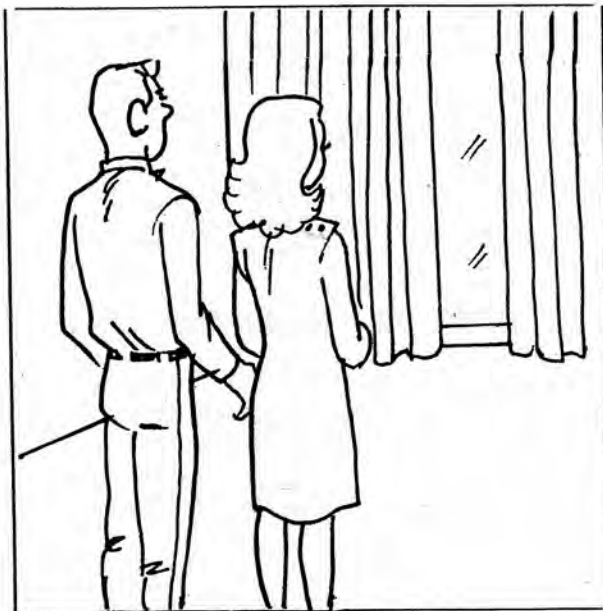
Figure 1

Someone answered Ken and Karrie's ad, and they found an apartment last week. It's located in the northwest district which is the part of town they wanted. They signed a one-year lease yesterday, so the apartment is theirs for one year. The electricity is supposed to be turned on today after they pay the deposit that is due. The owner told them that their rent will be due the fifth of each month. They were going to pick out the color of paint today, and Karrie decided she would dye the drapes a color to go with the paint. But they couldn't agree on the colors. They argued about it for awhile at the paint store, but the argument didn't last too long. They finally agreed on the colors, and Karrie will get the dye tomorrow. They are happy with their apartment, and there's lots of privacy because there are no neighbors close by.

Figure 2

- a. _____ a lease for the apartment
- b. _____ because there are no neighbors close by
- c. _____ the electricity today
- d. _____ pick out the color of the paint
- e. _____ change the color of the drapes
- f. _____ in the northwest district of town

.

Figure 3

1. couple	people	three	pair	group	kind
2. vehicle	instrument	building	computer	typewriter	car
3. weight	height	health	pounds	long	length
4. pain	cold	kind	heat	hurt	free
5. cash	chain	gold	money	match	chance
6. job	occupy	busy	college	career	build
7. fabric	paper	cloth	paint	glass	gold
8. school	mall	store	college	shop	class
9. document	ceremony	certificate	history	mail	photograph
10. tool	wrench	copper	gold	screen	keyboard

Figure 4

1. instrument	piano	car	college	photograph	antique
2. symphony	violin	university	orchestra	college	instrument
3. scared	loyal	afraid	behave	brave	break
4. width	high	long	wide	short	big
5. measurement	loyal	document	feet	long	heavy
6. jewelry	paper	bracelet	glass	hair	dress
7. weapon	gun	wallet	pencil	tool	team
8. wash	leather	lemon	humid	sheet	laundry
9. extra	add	spare	score	some	treat
10. musician	keyboard	violin	piano	instrument	singer
.					

Figure 5

1. Mark: Did you get change for that twenty-dollar bill?
Mike: Yes, George gave me four five-dollar bills.

Mark: But don't you need some one-dollar bills?
Mike: No, five-dollar bills are fine.
2. Greg: Do they live in a two-story house?
Gary: No, as a matter of fact, they live in a twelve-story apartment building.

Greg: I think I prefer a one-story house.
Gary: Oh, I wouldn't mind a two-story house, but I wouldn't like the twelve-story apartment building.
3. Tony: Do you want a two-door or a four-door car?
Troy: I prefer a four-door car. It's easier when you have people riding with you.

Tony: I guess so, but I like the looks of a two-door car better.
Troy: I'd choose the convenient four-door car over the good-looking two-door car.

Figure 6

1. yes/six-page/letter/family
2. twenty-story/apartment
3. yes/can/do/want/five-dollar/or/need/one-dollar/?
4. only/two-page
5. four-door
6. no/do/two/hundred-dollar
7. which/want/one-story/two-story/?
8. yes/two-hour/nap/after lunch

.

Figure 7

People like different kinds of _____. Some people like soft _____ comfortable sofas and chairs in _____ living room while others would _____ rather have beautiful antiques which _____ sometimes very hard and very _____. Modern furniture is usually more _____ than it looks. It's _____ to fit the form. _____ may be made of plastic _____ look hard, but because of _____ shape, it's comfortable.

Figure 7

People like different kinds of furniture. Some people like soft and comfortable sofas and chairs in their living room while others would much rather have beautiful antiques which are sometimes very hard and very uncomfortable. Modern furniture is usually more comfortable than it looks. It's made to fit the form. It may be made of plastic and look hard, but because of the shape, it's comfortable.

Figure 1

ANNOUNCEMENT A

1. Where are they selling the dinner rolls?
 - a. in the roll department
 - b. at the front of the store
 - c. out of the oven

2. What kind do they have?
 - a. wheat and sugar
 - b. bread and rolls
 - c. wheat and white

3. How much are they?
 - a. \$1.99 each
 - b. \$1.99 a dozen
 - c. \$1.99 a half dozen

ANNOUNCEMENT B

4. What is the announcement about?
 - a. students
 - b. graduation
 - c. uniforms

5. When will it take place?
 - a. Thursday, October 8, 1430 hrs
 - b. Thursday, October 14, 0800 hrs
 - c. Tuesday, October 8, 1400 hrs

6. Where will it take place?
 - a. Bldg 7548
 - b. Bldg 4875
 - c. Bldg 1430

ANNOUNCEMENT C

7. Where was the money found?
- a. in Seville Hall
 - b. in Lab 8
 - c. in Sgt Hall's office
8. Where can the owner claim the money?
- a. at Lab 8
 - b. at the lab office
 - c. at Sgt Hall's office
9. How can the money be claimed?
- a. by describing Seville Hall and identifying the lab number
 - b. by identifying the building number and describing the amount of money
 - c. by identifying the lab number and describing the amount of money

ANNOUNCEMENT D

10. What have begun?
- a. team tryouts
 - b. Lackland tryouts
 - c. basketball tryouts
11. Who can try out for the teams?
- a. military men and women assigned to Lackland
 - b. only military men assigned to Lackland
 - c. only military women assigned to Lackland
12. Where can you get more information?
- a. at the hospital
 - b. at the athletic office
 - c. at the gym

Figure 2

1. For: _____

From: _____

Message: _____

2. For: _____

From: _____

Message: _____

3. For: _____

From: _____

Message: _____

Figure 3

EXAMPLE: know
Do you know if Sam has left for the office yet?
Do you know whether Sam has left for the office yet?

1. know
2. can tell me
3. have any idea
4. by any chance know
5. could tell me
6. have any idea
7. can tell me
8. know

.

Figure 4

EXAMPLE: don't know
I don't know how far it is to New York.

1. don't know
2. have no idea
3. can't tell
4. not sure
5. have no idea
6. not sure
7. don't know
8. don't remember

Figure 1

**FREE
OIL
&
FILTER
CHANGE**

**13-POINT
VEHICLE
INSPECTION**

**NOW
\$19⁹⁵**

**10% DISCOUNT
ON NEXT
FACTORY
RECOMMENDED
MAINTENANCE**

**COOLING
SYSTEM
SPECIAL**

**NOW
\$24⁹⁵**

OWNER
| NORTH |

HOURS:
Mon. — Fri.
7 AM to 6 PM

NORTH AUTOMOBILES

12345 SAN PEDRO

555-0608

Figure 2

1. _____
 2. _____
 3. _____
 4. _____
 5. _____
-

Figure 3

1. yes/white
2. no/hold/door/open/please
3. how/keep/food/cool/?
4. drink/coffee/black/?
5. yes/everyone/consider/intelligent
6. no/unfurnished
7. no/green
8. can/leave/door/?
9. no/made/sad
10. got/clothes/wet

Figure 4

a/c = air conditioning	pd = paid
appl's = appliances	pub trans = public transportation
apt = apartment	rm = room
avail = available	schls = schools
bdrm, br = bedroom	shp cent = shopping center
c/a/h = central air & heat	sml = small
fencd = fenced	3/2/1 = number bedrooms/number bathrooms/number cars that will fit in garage
furn = furnished	unfurn = unfurnished
immed = immediately	util's = utilities
incl = included	w/ = with
lg(e) = large	yd = yard
mo = monthly	yr = year
mod = modern	
nr = near	

.....

Figure 5

EXAMPLE: Wanted: 2 bdrm apt, nr schls.

1. _____
2. _____
3. _____
4. _____

Figure 6

EXAMPLE: Wanted: 2 bdrm apt, nr schls
Wanted: 2-bedroom apartment, near schools

1. Sml, unfurn 1 bdrm apt, util's pd, avail immed

2. Wanted: sm, a/c house w/ fencd yd, nr shp cent, pub trans avail

3. Wanted to buy: House w/ 3/2/1/, c/a/h, lg yd, nr schls, avail by Sept 1

4. For Rent: lg, mod, a/c, 2 bdrm house, lg appl's incl, util's pd, sm yard

Figure 7

1. FURNITURE

A. Early American

B. _____

C. _____

2. RENT REQUIREMENTS

A. _____

B. Monthly payment

C. _____

3. VACATIONS

A. _____

B. Going to the Sea

C. _____

4. KINDS OF TRAVEL

A. _____

B. _____

C. By car

5. THE ARMED FORCES

A. _____

B. _____

C. _____

D. _____

E. Coast Guard

ANSWERS FOR TAPE 2D, BOOK 17

Figure 5

1. For rent: lg, mod, 3-bdrm house, avail immed, nr schls, lg yd
2. Sm 1-bdrm apt avail, appl's furn, util's incl
3. 2-yr lease: unfurn, mod apt, c/a/h, lg appl's furn
4. Wanted: sm, a/c apt w/ lg appl's furn, util's pd

Figure 1



Discipline is a very important part of a soldier's training. A soldier who can't learn discipline will never be able to work successfully in the military. New soldiers must learn to listen to orders and follow them. They must learn about correct military appearance. They need to learn how and where to display their insignia on their caps and uniforms. They need to learn how to display respect to their superiors. They have to learn when and where and how to salute. In general, they need to know how to act in a disciplined, military way. A soldier who has discipline is easier to work with than a soldier with no discipline because he can be depended on to do what he is supposed to do. He knows that rules are mandatory and he must follow them. His leader has indicated to him what he has to do, and he does it. He doesn't have to be shown twice.

Figure 2

1. a. He does what he is supposed to do.
b. He doesn't always follow orders.
2. a. You shouldn't spend a lot of money in that part of town.
b. You shouldn't show a lot of money in that part of town.
3. a. They learned discipline from their father.
b. They learned distances from their father.
4. a. They told the soldiers what they wanted them to do.
b. They asked the soldiers what they wanted to do.
5. a. Rules must be followed by military persons.
b. Rules must be made by military persons.
6. a. The young man looked for a neat appearance.
b. The young man looked neat and clean.

Figure 3

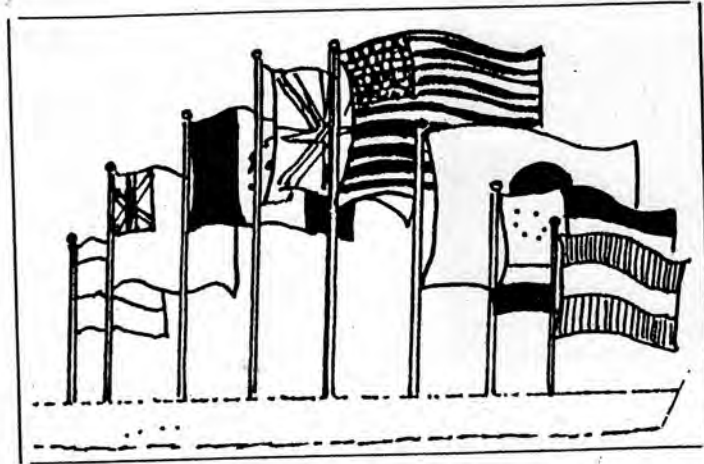

1. There are a lot of flags in front of that building.

Most countries have a flag.

Flags are symbols of nations.

When we see a white flag with a red leaf, we know it is the flag for the nation of Canada.

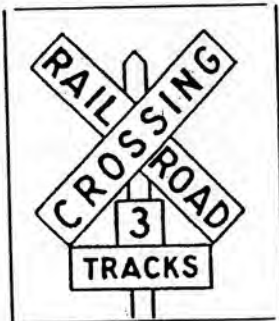

2. This symbol tells us there's a railroad crossing ahead.



3. A national anthem is a country's song. When you hear a national anthem, you should stand up. Do you know all the words to your national anthem?

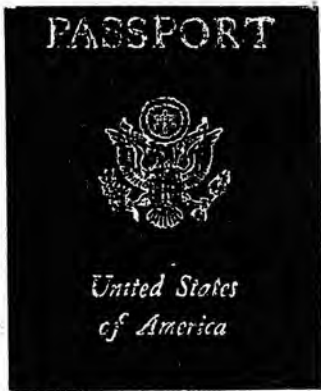

4. Your passport is an official document.
It was given to you
by your government.

5. The barbecue was an informal gathering.



6. The general's reception was a formal occasion.

Figure 4

- | | | | |
|----|---------------------------|----|--------------------------|
| 1. | a. a display | 2. | a. a song |
| | b. a flag | | b. a flag |
| | c. a gathering | | c. a club |
| 3. | a. his military uniform | 4. | a. an informal gathering |
| | b. formal clothes | | b. a formal occasion |
| | c. informal clothes | | c. an official display |
| 5. | a. You should sing along. | | |
| | b. You should sit still. | | |
| | c. You should stand up. | | |

.

Figure 5

1. Classes must be attended daily.
2. Students will be expected to be on time.
3. A student might be questioned about being late.
4. Reasons for being late don't have to be accepted by the instructor.
5. Students have to be given homework.
6. The lesson for the next day ought to be looked over the night before.
7. Review quizzes can be given every morning.
8. Extra class time may be required.
9. The BX can be gotten to very easily by bus.
10. If you shop at the BX in civilian clothes, you could be asked to show your ID card.
11. Shopping should not be done for civilians who can't shop at the BX themselves.

Figure 6

EXAMPLE: traffic rules/must/obey
Traffic rules must be obeyed (by drivers).

1. driver/might/stop
2. could/ask/out of/car
3. traffic signals/can/see
4. cars/should not/drive/with/seat belts/unfastened
5. cars/have to/inspect
6. licenses/ought to/get
7. licenses/not have to/give/everyone
8. cars/can/drive/careful
9. fines/will/pay/break laws
10. accidents/may/avoid/drive/careful

Figure 7

EXAMPLE:	red	blue	<u>paper</u>	green	yellow	black
1.	sergeant	lieutenant	general	secretary	major	
2.	handsome	attractive	pretty	beautiful	friendly	
3.	curly	wavy	elderly	straight	bald	
4.	blond	brunette	redhead	curly	gray	
5.	selfish	dependable	honest	generous	reliable	
6.	pants	mustache	necktie	shirt	hat	
7.	thirsty	toothpaste	teeth	tooth	toothbrush	
8.	width	height	long	measure	short	
9.	capable	smart	clever	sweet	sharp	
10.	picnic	vehicle	dance	party	movie	

Figure 1

Officers' Club						
Sun.	Mon.	Tue.	Wed.	Thurs.	Fri.	Sat.
June 5 Champagne Breakfast 12	6 A 13 B 20 C 27 D	2-4-1 7 STEAK NITE 14 A 21 COMBINATION BROILED CHICKEN BREAST COD FISH ALMONDINE 28 A 35 B 42 C 49 D	8 EVERY WED. NITE 15 FEATURES A SPECIAL HEALTHY 22 HEART MENU FROM 29 6-9:30 PM 36 E	9 F 16 G 23 H 30 I 37 J 44 K 51 L	LITTLE JOE & VIPS 17 THE LATE SHOW 24 Jo ANNA 31 STEAK OR SEAFOOD SPECIAL 38 M 45 N 52 O 59 P 66 Q 73 R 80 S 87 T 94 U 101 V 108 W 115 X 122 Y 129 Z	11 ROD'S GOOD TIME MUSIC 18 Angel Morales 25 MUSIC AMERICA 2 Genny Snyder
FATHER'S DAY! 9 1 2 Champagne Breakfast	REMEMBER DAD ON... FATHER'S DAY JUNE 19!	JOIN YOUR FRIENDS AT THE CLUB!				

Certain things are expected of military personnel as a part of their daily lives. One thing they are expected to do is participate in the activities of their clubs. If they are officers, they should eat some meals at the Officers' Club and if there is a party there, they are expected to go. If they are NCOs, they participate in games, parties, and gatherings at the NCO club. They support their clubs by attending them and also by paying money. A nice thing about the clubs is that they give military personnel a chance to associate with each other. They can talk, eat, and enjoy themselves together. A club is a nice place for them to gather together and it's not too expensive. Military officials do not make officers and NCOs join these clubs, but it is expected of them.

Figure 2

- 1. a. He watched two sports.
b. He played two sports.
- 2. a. They belong to a music club.
b. They attend concerts every month.
- 3. a. He supports the ballet.
b. He associates with the ballet.
- 4. a. They gather in the offices after work.
b. They associate with each other after work.
- 5. a. Bill is a city official.
b. Bill works for the city.

Figure 3



Respect for our national flag and the national anthem is rendered on military bases at a ceremony called Retreat. Retreat is the ceremony at which the flag is lowered at the end of the day. The commander of a base governs the time for Retreat. He decides when it should take place. The ceremony sometimes includes a parade--some of the best trainees may march--but not always. The sound of guns and the playing of the national anthem are indications that the flag is being lowered even if you can't see it. Participation in the ceremony is mandatory for all military personnel, even those who are across the base. They must stop what they are doing, stand at attention, and salute. If they are in civilian clothes, they should remove their hats and place their right hands over their hearts.

Figure 4

1. a. He's going to see the base commander retire.
b. He's going to see the flag lowered.
2. a. He wants to know who the leader of that country is.
b. He wants to know what the symbol of that country is.
3. a. They enjoyed watching the retirement ceremony.
b. They enjoyed watching the parade.
4. a. They were the signs of rain.
b. They were the cause of rain.
5. a. Participation was by all of the students.
b. Discipline was by all of the students.

LANGUAGE LABORATORY ACTIVITIES, TAPE 3C

Figure 1

<u>ARMY</u>	<u>MARINE CORPS</u>	<u>NAVY</u>	<u>AIR FORCE</u>
Warrant Officer (W-1)	Warrant Officer (W-1)	Warrant Officer (W-1)	
Chief Warrant Officer (W2-4)	Chief Warrant Officer (W2-4)	Chief Warrant Officer (W2-4)	
Staff Sergeant Major (SSM)	Sergeant Major (SgtMaj)	Master Chief Petty Officer (MCPO)	Chief Master Sergeant (CMSgt)
First Sergeant (1 Sgt)/Master Sergeant (MSG)	First Sergeant (1 Sgt)/Master Sergeant (MSgt)	Senior Chief Petty Officer (SCPO)	Senior Master Sergeant (SMSgt)
Platoon Sergeant (PSG)	Gunnery Sergeant (SSgt)	Chief Petty Officer (CPO)	Master Sergeant (MSgt)

EXAMPLE: T F

1. T F

2. T F

3. T F

4. T F

5. T F

6. T F

7. T F

8. T F

Figure 2

Ahmed: Ali found out _____ for gifts for his family.

Peter: Did Mike show him _____ to?

Ahmed: Yes, but he still doesn't know _____ for his sister.

Peter: Did Ali ask Mike _____ for her?

Ahmed: Mike didn't know _____ him.

Peter: Has Ali decided _____ the gifts?

Ahmed: He can't decide _____ them there. He doesn't know whether to mail them or wait until he can take them.

Peter: If he waits, maybe he'll decide _____ for his sister.

Figure 3

Steve: Did you forget _____ Sam?

Henry: He told me _____ him but not where!

Steve: Are you sure? Maybe you just don't remember
_____.

Henry: I remember because he told me he'd teach me
_____ good fruit but he didn't say
in which store.

Steve: Well, in how many stores could you learn
_____ good fruit?

Henry: In more stores than you think! I guess I'll just wait
until he calls and then decide _____.

Figure 4

EXAMPLE: I don't know which to use myself. (use)

1. I don't know _____ myself. (wear)
2. I don't think Mabel has decided _____ with her car. (do)
3. Yes, he asked the doctor _____ his medicine. (take)
4. Did Sam find out _____ good fruit, too? (buy)
5. Did he show you _____ it? (use)
6. Yes, but I've forgotten _____ there. (get)
7. Did he teach you _____ the lab? (use)
8. Yes, she learned _____ French in France. (speak)
9. No, and I don't remember _____ them. (find)
10. Good. Ann told me _____ them. (cook)

Figure 5

ANNOUNCEMENT A

1. Where will the gathering be held?

2. What time will they meet?

3. Why are they celebrating?

ANNOUNCEMENT B

1. What will be given?

2. When will it be given?

3. Where will it be given?

4. Who is to take the test?

ANNOUNCEMENT C

1. Who is the announcement for?

2. When will the game be played?

3. When can they sign up?

4. Where will the game be played?

5. Where do they sign up?

Figure 1

1. Sgt Majors _____.
 - a. participates in the activities
 - b. governs the activities
 - c. watches the activities

2. They're looking at _____.
 - a. Washington, D.C.
 - b. the Retreat ceremony
 - c. the flag

3. The soldiers _____.
 - a. joined the club
 - b. displayed the flag
 - c. did what they were supposed to do

4. John _____.
 - a. always shows a lot of discipline at the club
 - b. participates in activities and gives money to the club
 - c. prefers informal gatherings to formal ones

5. The major said _____.
 - a. the meeting would be relaxed
 - b. the meeting would need a lot of rules
 - c. the meeting would need to be very disciplined

6. The captain said they _____.
 - a. don't have to go to the parade
 - b. must go to the parade
 - c. ought to go to the parade

7. The national flag should be _____.

- a. before the others
- b. after the others
- c. with the others

8. The commander decided the time for _____.

- a. flying the flag
- b. raising the flag
- c. lowering the flag

.....

Figure 2

1. Even though the speed limit is 65, many people drive faster.

2. I like my house even though I pay a lot of money for it.

3. I like Mr. Winters although he gives a lot of homework.

4. Although I don't like hot weather, I continue to live in Texas.

5. Though small cars cost less, I prefer big cars.

6. I eat a lot of sweets though I know they're not good for me.

Fig

1.

2.

3.

4.

5.

6.

7.

8.

9.

10.

11.

12.

Figure 3

1. Smoking can be dangerous. People still do it.
2. It was raining. The football game continued.
3. Swimming is good exercise. Some people don't enjoy it.
4. I like war movies. They make me cry.
5. Some people don't like to exercise. It's good for them.
6. I like this city. The weather isn't good.
7. I plan to finish this today. It means working late.
8. Bob studies hard. He doesn't make good scores.
9. Mary is good with children. She doesn't have any of her own.
10. David makes a good salary. He can't seem to save money.
11. I don't eat candy. I like it.
12. We left early. We were late for the movie.

Figure 4

1. What's taking place?
 - a. a Retreat ceremony
 - b. a parade
 - c. a retirement ceremony

2. What did she do?
 - a. demanded someone he knew
 - b. described someone he knew
 - c. disciplined someone he knew

3. Where are they?
 - a. at the swimming pool
 - b. at the snack bar
 - c. at the gymnasium

4. Where are they?
 - a. at a ceremony
 - b. at a meeting
 - c. at a party

5. Where are they?
 - a. at a club
 - b. at a party
 - c. at a meeting

6. What are they doing?
 - a. eating lunch
 - b. trying on clothes
 - c. shopping for shoes

7. What is he trying to use?

- a. a vending machine
- b. a telephone
- c. a computer

8. Where are they?

- a. at a formal dance
- b. at a birthday party
- c. at an official meeting

.

Figure 5

Military personnel are expected to do certain things. One thing they're expected to _____ is participate in the activities of their _____. If they are officers, they should _____ some meals at the Officers' Club and _____ there is a party there, they _____ expected to go. If they're NCOs, _____ participate in games, parties, and gatherings _____ the NCO club. They support their _____ by attending them and also by _____ money. A nice thing about the clubs _____ that they give military personnel a _____ to associate with each other.

Figure 5

Military personnel are expected to do certain things. One thing they're expected to do is participate in the activities of their clubs. If they are officers, they should eat some meals at the Officers' Club and if there is a party there, they are expected to go. If they're NCOs, they participate in games, parties, and gatherings at the NCO club. They support their clubs by attending them and also by paying money. A nice thing about the clubs is that they give military personnel a chance to associate with each other.

Figure

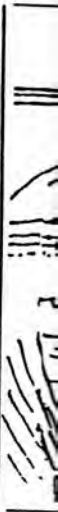
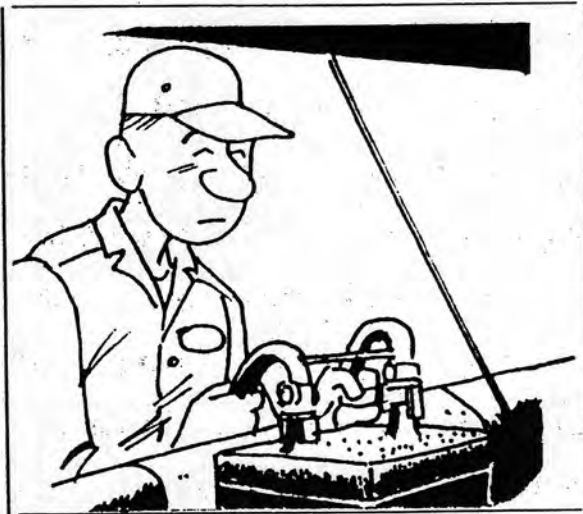
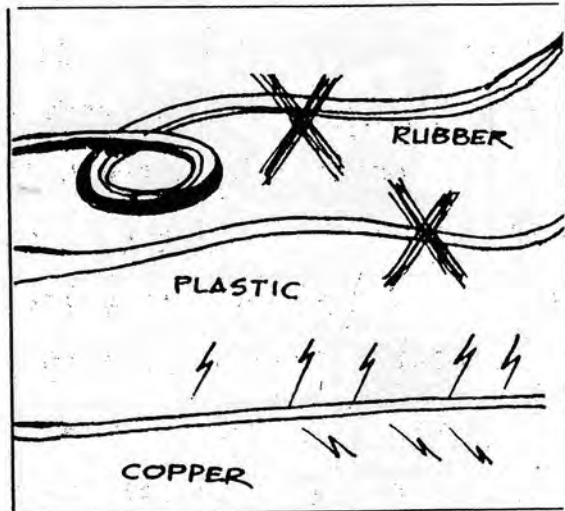

Figure 1



1. charge



2. conduct

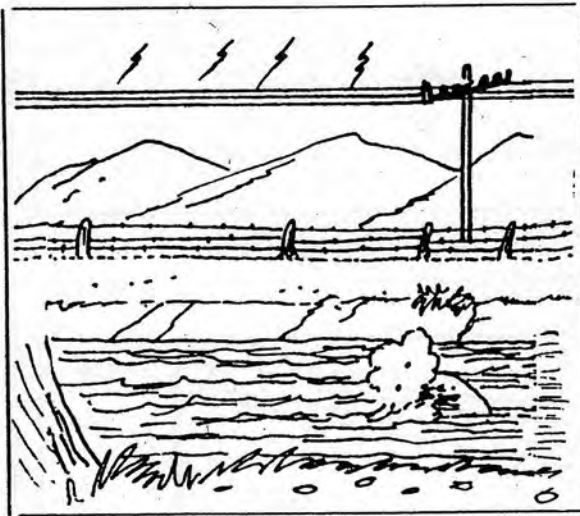

3. flow

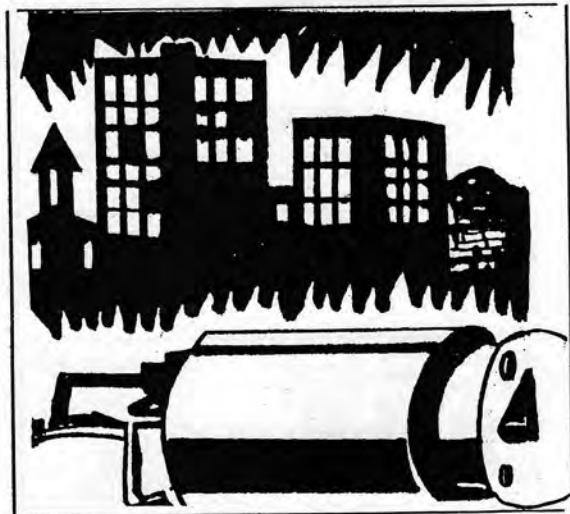

4. generate



5. insulate/insulated

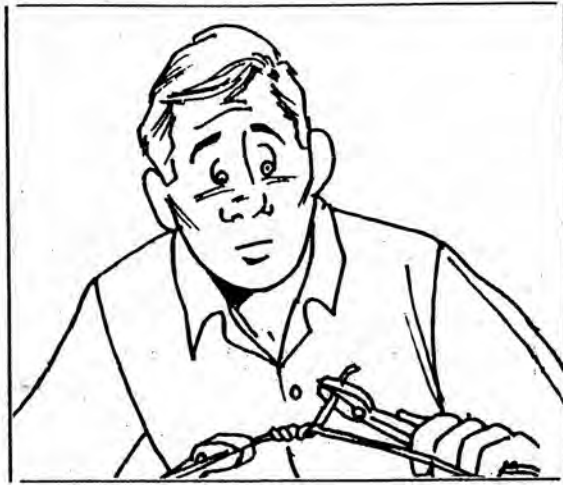

6. splice



7. aluminum

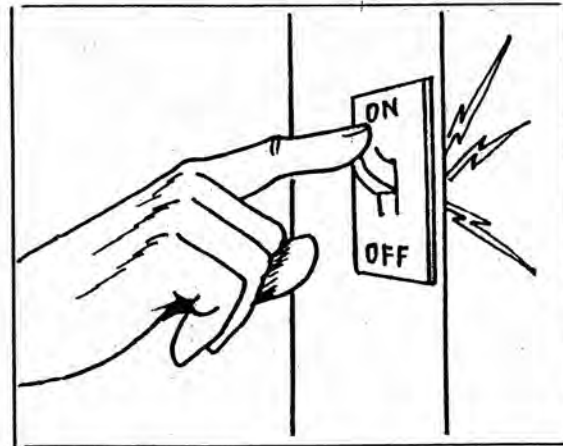

8. charge



9. conductor

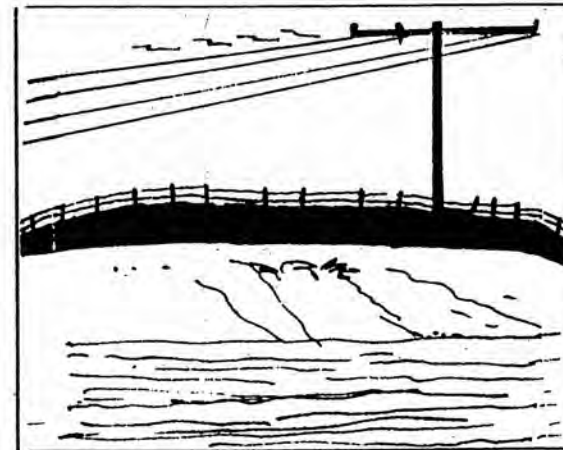

10. current

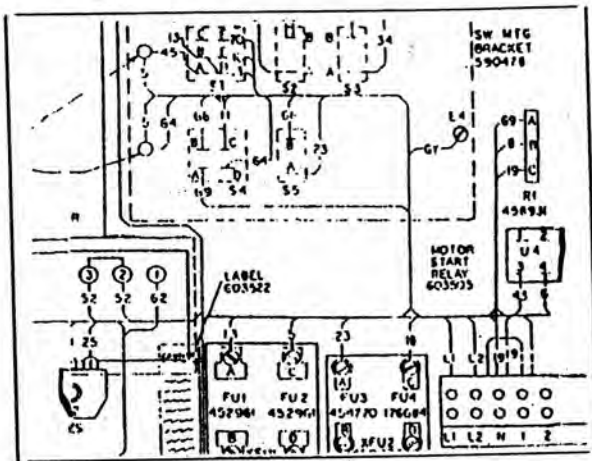

11. circuit

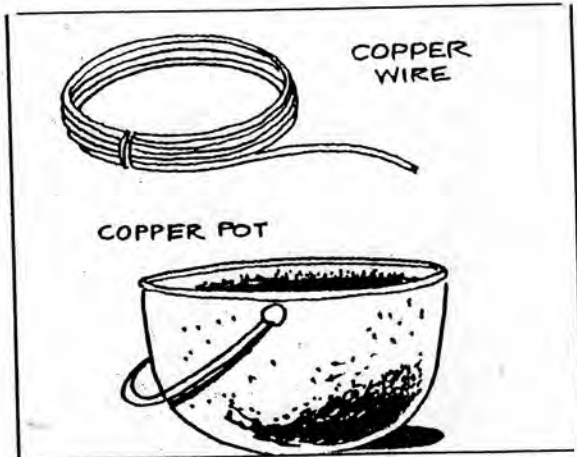

12. copper

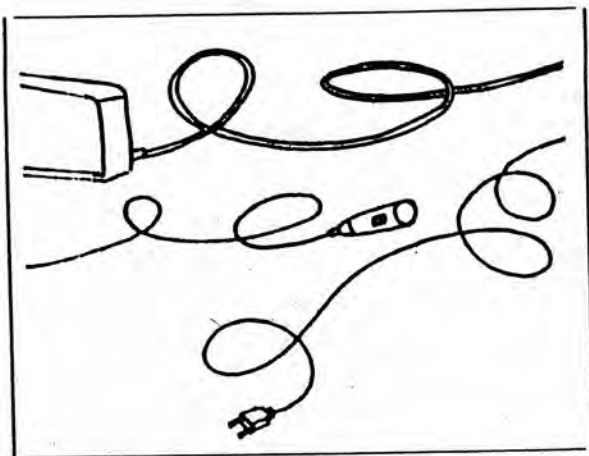

13. wire

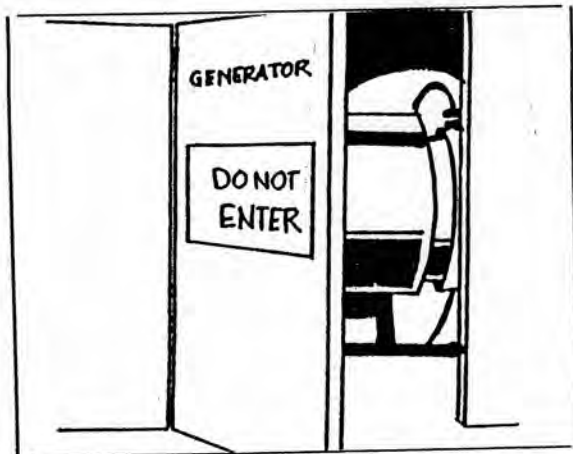

14. generator

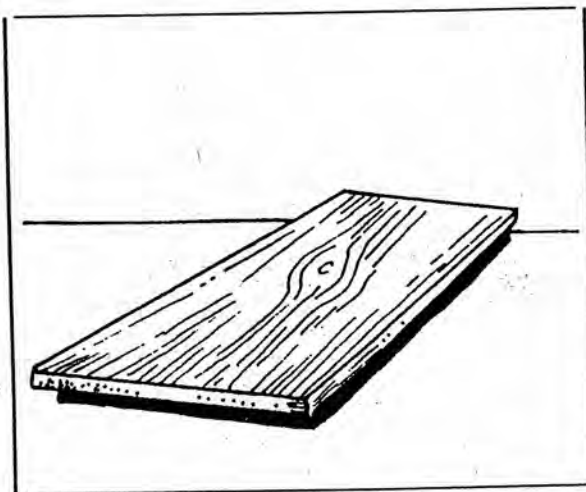

15. insulator/insulation

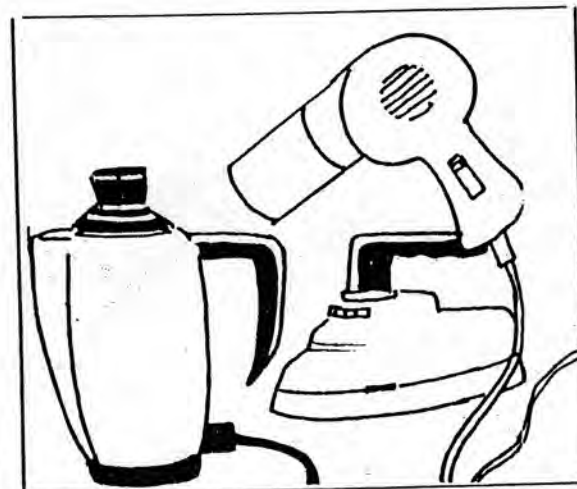

16. electric/electrical

Figure 2

EXAMPLE: This unit is all about _____.

- a. tools
- b. electricity
- c. metals

- 1. a. flowed
- b. insulated
- c. generated

- 2. a. conductors
- b. insulators
- c. generators

- 3. a. spliced
- b. charged
- c. conducted

- 4. a. insulators
- b. generators
- c. conductors

- 5. a. splice
- b. insulate
- c. charge

- 6. a. flows
- b. charges
- c. insulates

- 7. a. wire
- b. current
- c. circuit

- 8. a. copper
- b. aluminum
- c. rock

- 9. a. charged
- b. flowed
- c. conducted

.....

Figure 3



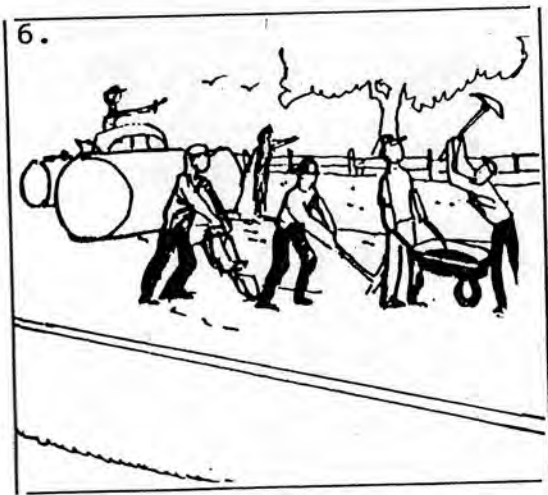

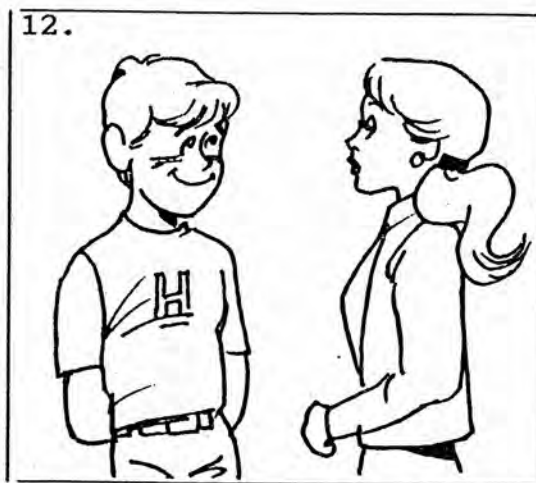
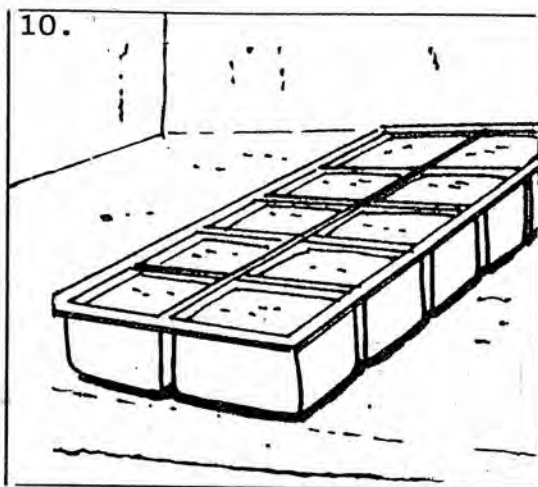
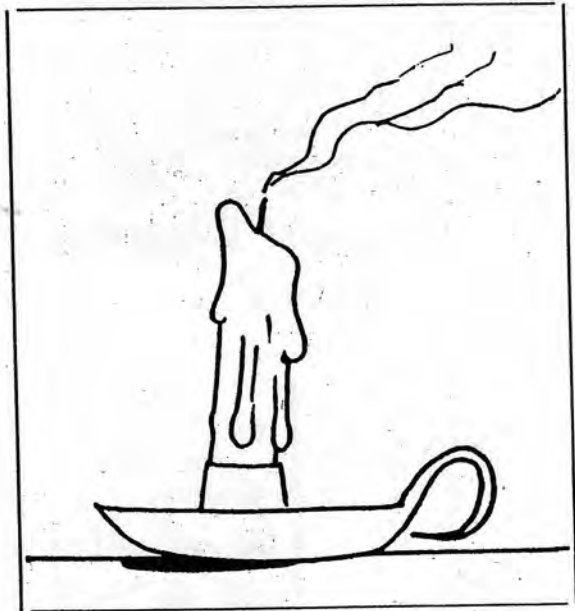

Figure 1



1. attach



2. go out/went out/gone out

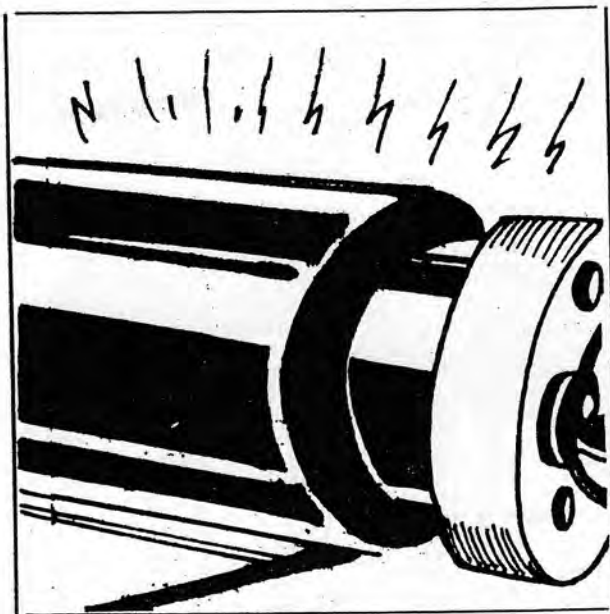

3. produces



4. protect

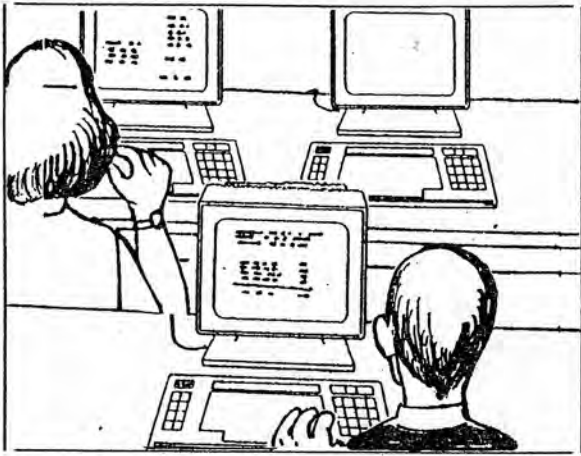

5. running

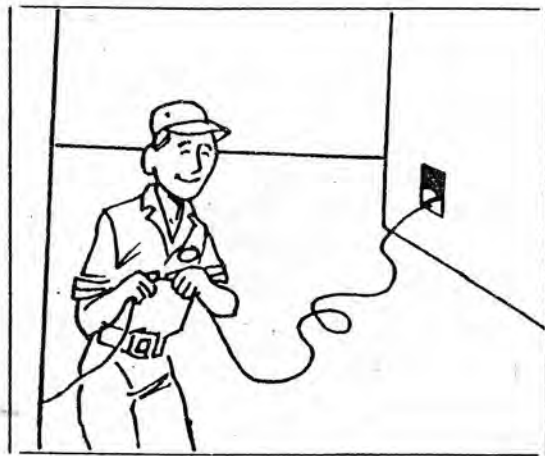

6. run



7. switch on/switch off



8. powerful



9. power

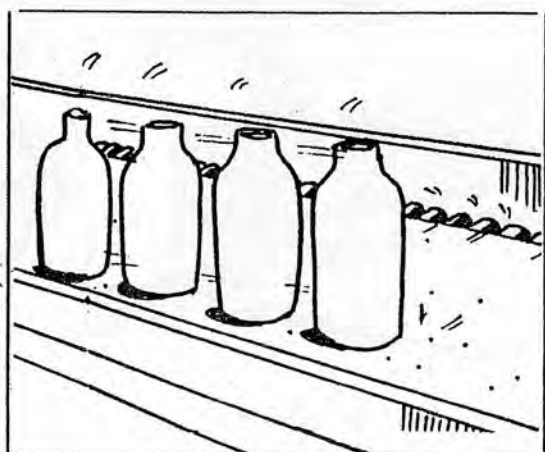

10. production

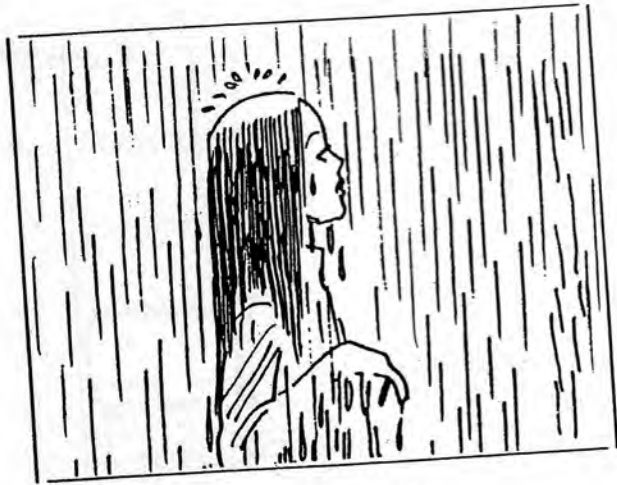

11. protection

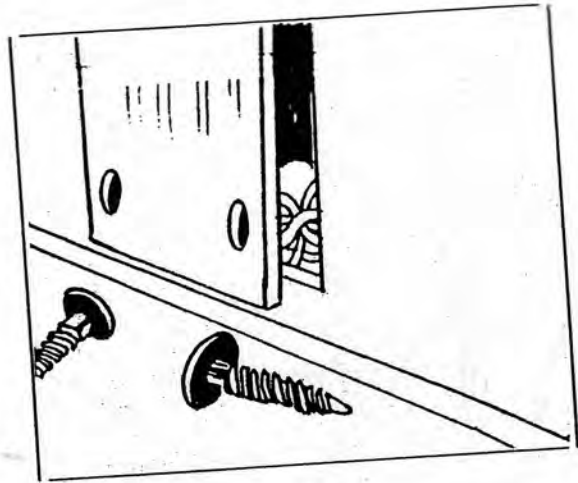

12. screw

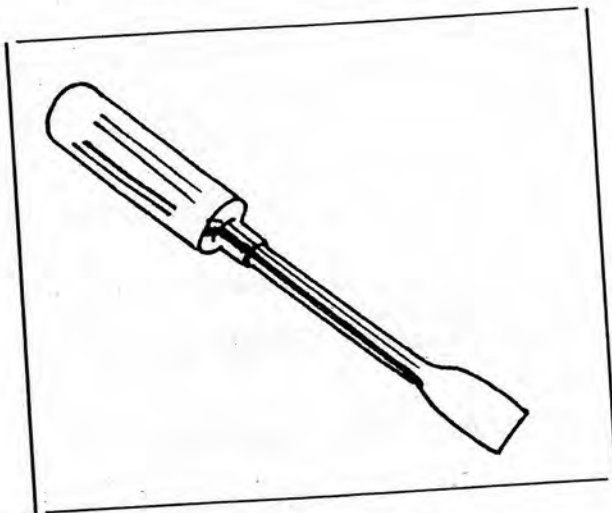

13. screwdriver



14. shock



15. short



16. switch



17. bare wire



18. use

1.

2.

3.

4.

5.

Figure 2

EXAMPLES: Roger doesn't want to go to Aunt Julie's house. I don't want to go to her house. (either)
Roger doesn't want to go to Aunt Julie's house and I don't either.

David didn't go to the party. John didn't go to the party. (neither)
David didn't go to the party and neither did John.

1. Johnny can't finish his dinner. I can't finish mine.
2. I'm not driving in this storm. Dana isn't driving in this storm.
3. George is not staying late again tonight. Bob's not staying late tonight.
4. They aren't paying extra for this. We aren't paying extra for this.
5. Tim's not jogging tonight. I'm not jogging tonight.
6. Lt Ross can't go to the retirement party. Capt Thomas can't go to the party.

Figure 3

1. When does the International Fair start?

2. When does it end?

3. How much does it cost to enter?

4. Can you eat there?

5. What are the hours of the Fair?

Figure 1

1. You're going to the party tonight, aren't you?
2. It's hot in here, isn't it?
3. Kevin's going to New York, isn't he?
4. I'm not interrupting anything, am I?
5. Nancy shouldn't try moving that sofa by herself, should she?
6. There wasn't anybody here when you arrived, was there?
7. Your sister didn't swim yesterday, did she?
8. The students studied for this test, didn't they?
9. Tommy walks to school, doesn't he?
10. Harry ate some of the dessert, didn't he?

Figure 2

EXAMPLES: It's cold in here, isn't it ?

You mailed that letter, didn't you ?

1. Fred _____ lock that door, _____ ?
2. Tomorrow _____ Sue's last day, _____ ?
3. You _____ Neil about the meeting, _____ ?
4. Diane _____ going to the movie with us, _____ ?
5. Lt Frye _____ on leave, _____ ?
6. We _____ leave now to get there by 7:30, _____
_____ ?
7. You _____ at Jack's party, _____ ?
8. _____ driving this week, _____ ?
9. Sam _____ two miles every day, _____ ?
10. You _____ tell Jean about the party, _____ ?
11. Pam _____ yesterday, _____ ?

Figure 3

John:

Frank: Where are you going?

John:

Frank: For how long?

John:

Frank: It sounds great! When are you leaving?

John:

Frank: We'll have to get together before you go.

.

Figure 4

John: Frank, I got my orders today.

Frank:

John: I'm going to Japan.

Frank:

John: It's a two year tour. It'll be my first time overseas.
I'm really looking forward to it.

Frank:

John: I report for duty there on the third of October.

Frank:

Figure 5

1. Where will the NCO luncheon be?

2. What day will it be?

3. Are there still tickets available?

4. Who can you contact if you need a ticket?

1.
2.
3.
4.
5.
6.
7.

Figure 6

1. What city is the tour to?

2. What day does the tour leave?

3. What time will the bus leave from Building 7342?

4. When does the tour return?

5. What's the fee for this tour?

6. What does this fee include?

7. How many seats are available?

Figure 7

- _____ a. the best conductor of electricity
- _____ b. a way of putting two wires together
- _____ c. a cheaper conductor than copper
- _____ d. turn on
- _____ e. strong
- _____ f. wood, plastic, and rubber
- _____ g. wires with no insulation

Fi
Cle
Cle
Cle
Fig
Cle
Cle
Cle
Fig
Ann
Jan
Ann
Jan
Ann
Jan

Figure 1

Clerk:

Ed: My name is Ed Wilson. I'd like to confirm my reservations for next Wednesday afternoon on Flight 372.

Clerk:

Ed: Thank you. I'll see you next Wednesday.

Clerk:

.

Figure 2

Clerk: Hello, Trans Global Airlines. How may I help you?
Ed:

Clerk: Okay, sir. Wait one minute while I check. Yes, sir. We have you down for Wednesday afternoon, Flight 372, departing at 1:32 and arriving in St. Louis at 4:14.
Ed:

Clerk: Thank you for calling Trans Global Airlines.

.

Figure 3

Ann:
Jan: Yes, we'll be there about 6:30.

Ann:
Jan: No, I'm bringing a dessert.

Ann:
Jan: Great! See you there.

Figure 4

Ann: You and Keith are going to Pete's dinner party, aren't you?
Jan:

Ann: And you're bringing a salad, aren't you?
Jan:

Ann: Oh! It's a good thing that I asked. Okay, I have you down
for a dessert.
Jan:

.

Figure 5

John:
Jack: No. Don't worry. It's a dead wire.

John:
Jack: Not yet. I'll do that right now.

.

Figure 6

John: Hey, Jack! Be careful!! That's a live wire, isn't it?
Jack:

John: You didn't switch off the current in the other room, did
you?
Jack:

Figure 7

A. Secretary

1. Person hired

- a. _____
- b. _____
- c. _____
- d. _____

2. Person not considered

- a. _____
- b. _____
- c. _____
- d. _____
- e. _____

.....
Figure 8

A. Without vehicles

- 1. _____
- 2. _____
- 3. _____
- 4. _____
- 5. _____

Figure 9

.....

Figure 10

1. When will the parade be held?

2. Will there be a reception after the parade?

3. Where will the reception be?

4. Who can you contact if you need more information?

Figure 11

1. How many tapes have you listened to from Book 17, Lesson 4?

2. Have you worked hard on these tapes?

3. What arrangements has your instructor made for you?

4. Where can you take this break?

5. Who should you contact if you need more information?

Figure 7

A. Secretary

1. Person hired
 - a. friendly
 - b. reliable
 - c. honest
 - d. hardworking
2. Person not considered
 - a. dishonest
 - b. unfriendly
 - c. selfish
 - d. demanding
 - e. messy

.

Figure 8

A. Without vehicles

1. couldn't ride a bus
2. couldn't fly a plane
3. couldn't ride a train
4. couldn't drive a car
5. would take a long time to get places

.

Figure 9

Jim's really a nice man. He's responsible and clever. I know I can rely on him for everything. In fact, he's the only one I trust to do my job while I'm away on vacation.